

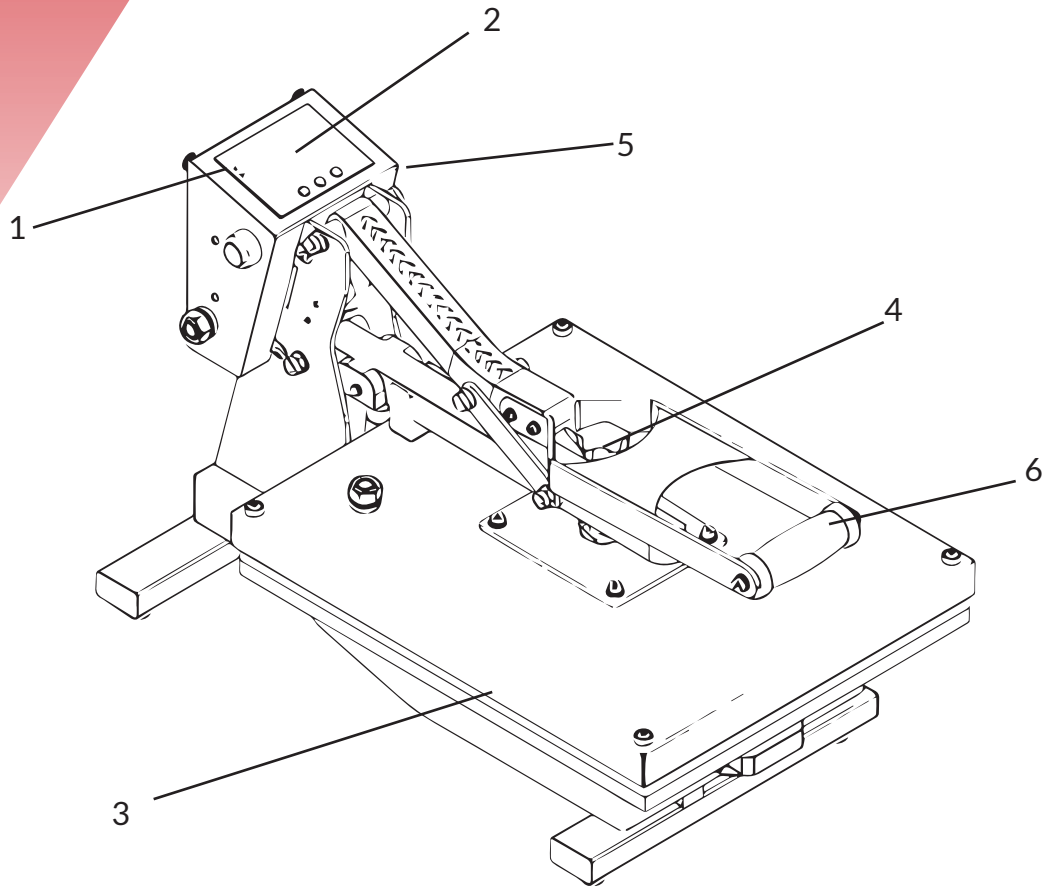

Contents:

1. Assembly drawing	Page 2
2. Technical Specifications	Page 3
3. Operating Process	Page 4 -6

1 - Assembly Drawing



1. Control Box
2. GY-06 Digital Controller
3. Heat Platen (40 x 60cm)
4. Pressure Adjust Knob
5. Power Switch
6. Operator Handle

2 - Technical Specifications

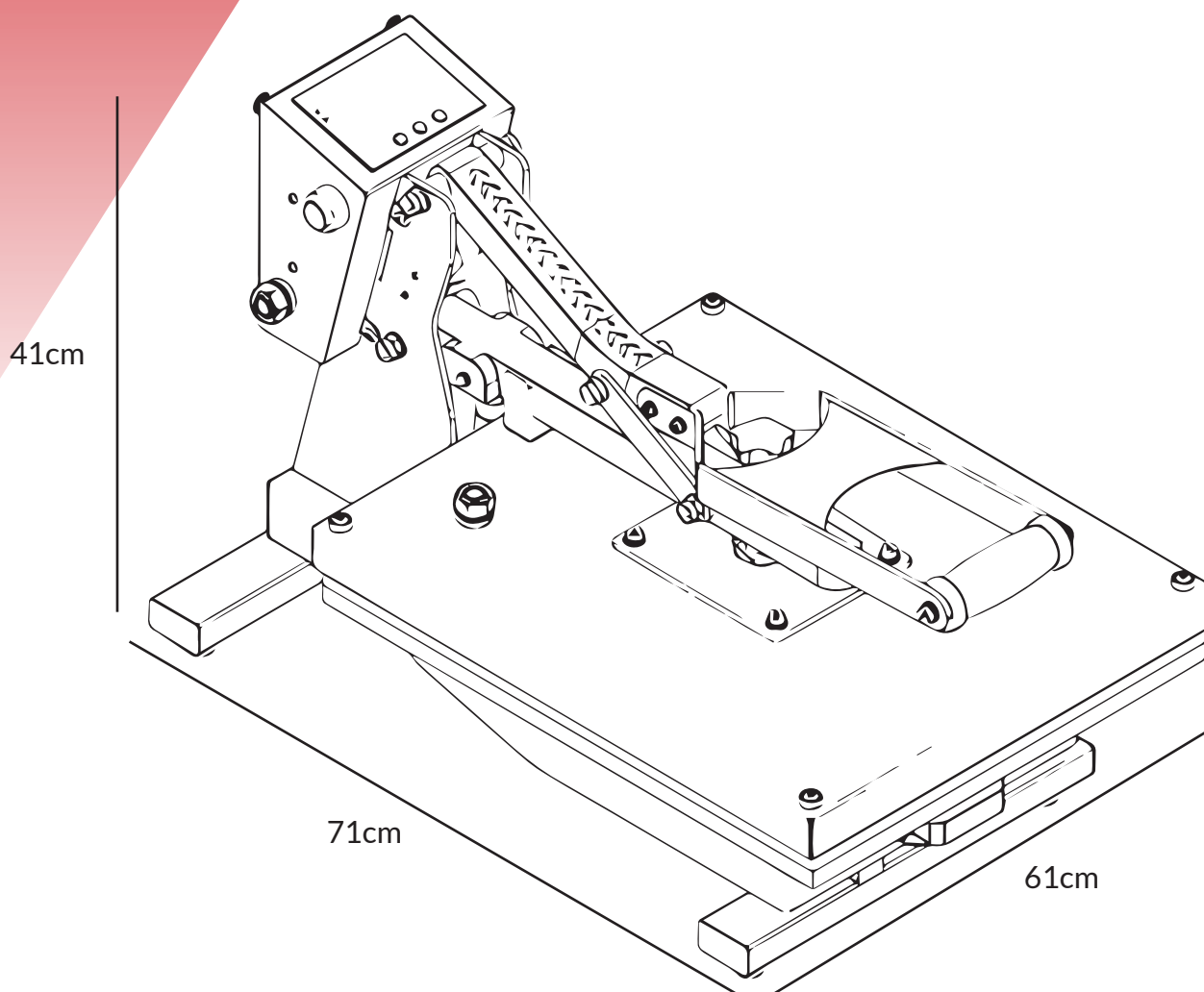

Technical Specification

Power consumption	1.8/1.2 kW
Voltage	220 V
Heat platen size	40 x 60cm
Printable articles maximum size	40 x 60cm
Time settings	0 - 999 sec
Maximum temperature	225°C

Dimensions

Machine dimensions 61cm (w) x 71cm (d) x 41cm (h)
Gross Weight 70kg

3 - Operating Instructions

3.1 Introduction to the Control Panel

Below is a diagram of the control panel of your heat press; from here, you will control all the functions of your press.

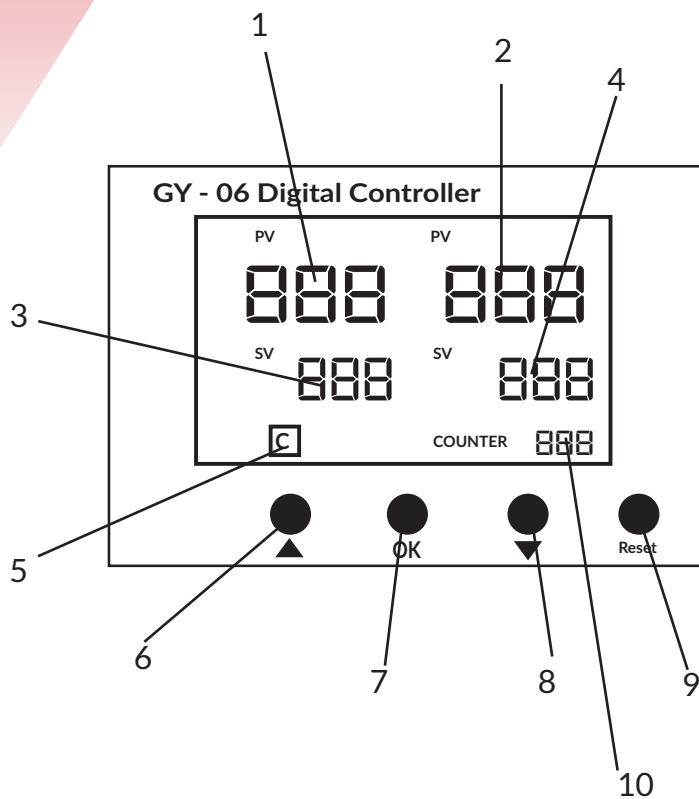

1. Current Temperature Display
2. Remaining Time Display
3. Set Temperature Display
4. Set Time Display
5. Current Temperature Unit
6. UP operation Button
7. OK Button
8. DOWN operation Button
9. Reset Button
10. Cycle Counter

3.2 Power ON the Heat Press

1. Connect your heat press to mains power using the power cable provided.
2. The press can now be turned on using the main power button located on the side of the press.



INFORMATION!

When the press is powered on, the digital display will display blank, as shown to the right.

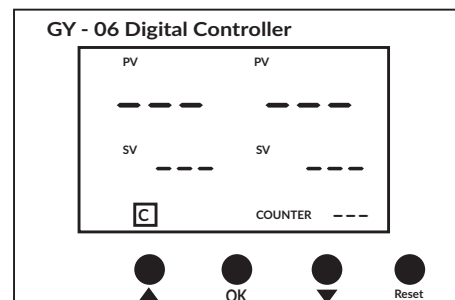

3 - Operating Instructions

3.3 Setting the Pressing Temperature

1. Press the OK button (7) on the control panel, and the screen will display "C" (5); this indicates that the press is set to operate in degrees Celsius.

2. You can select between degrees Celsius and degrees Fahrenheit by pressing the UP / DOWN operation buttons (6/8)

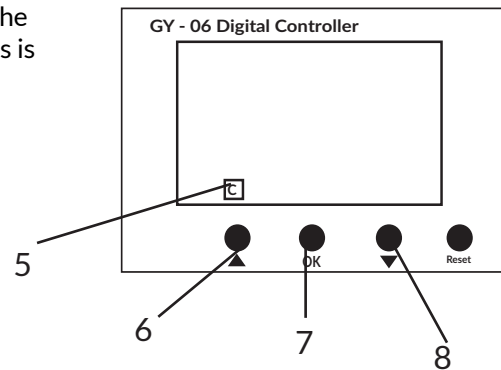

3. Press the OK button (7) again, and the screen will display the target temperature for the press (3).

4. Use the UP/DOWN operation buttons (6/8) to select your desired pressing temperature.

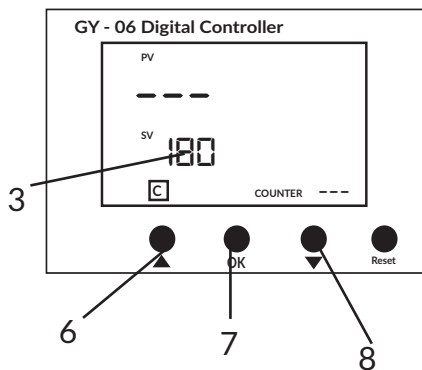

3.3 Setting the Pressing Time

1. Press the OK (7) button again and the digital display will show the current press time setting (4).

2. Use the UP/DOWN operation buttons (6/8) to select your desired pressing time.

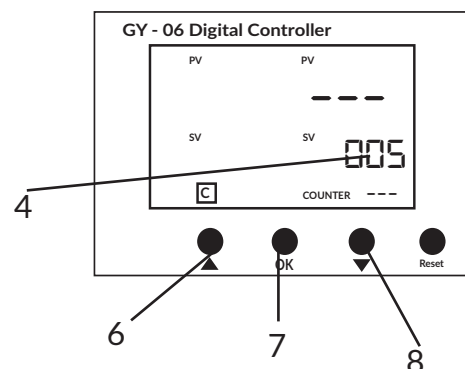

3. Press the OK (7) again to confirm your settings. The display will change to show the current temperature of the press; this will begin to climb up to the desired temperature.

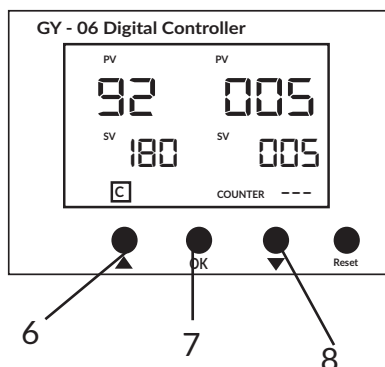

INFORMATION!

Once set, the timer will begin to count down. The countdown LED (5) will light up when the heat press is closed. An alarm will sound when the press cycle is complete, and the press will open automatically.

3 - Operating Instructions

3.4 Setting the Pressure

You must change the force that the press applies to suit the substrate being used. Follow the steps below to adjust the pressure.

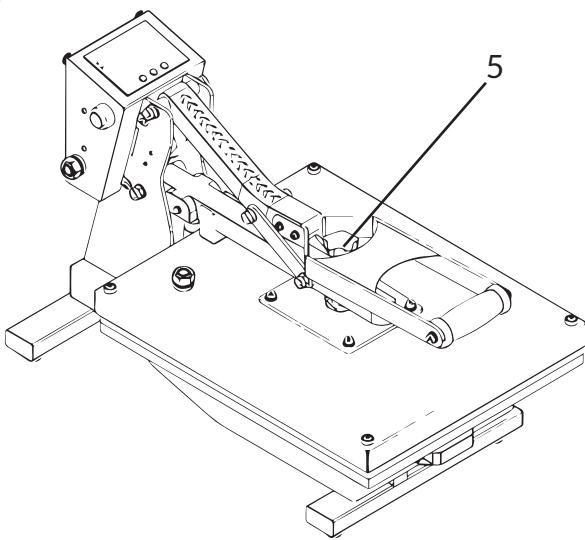

1. Before adjusting the pressure knob (5) located under the attached lower platen. Ensure that the press is in the open position.

2. With the press open, turn the pressure knob (5) to adjust the pressure. Clockwise increases the pressure, and counter-clockwise will lower the pressure.



Clockwise will increase the pressure



Anti-Clockwise will decrease the pressure

If you have any further questions about the operation of your heat press, please do not hesitate to contact our Tech Support Team using the details below



+44 (0) 01228 712128



techsupport@primaheatpresses.com

